

Profile

- Resolutions of max. 2560 pulses/revolution
- Hollow shafts up to $\varnothing 22$ mm, stainless steel
- Protection category IP65
- Aluminum housing
- Condensation permitted with sealed electronics unit

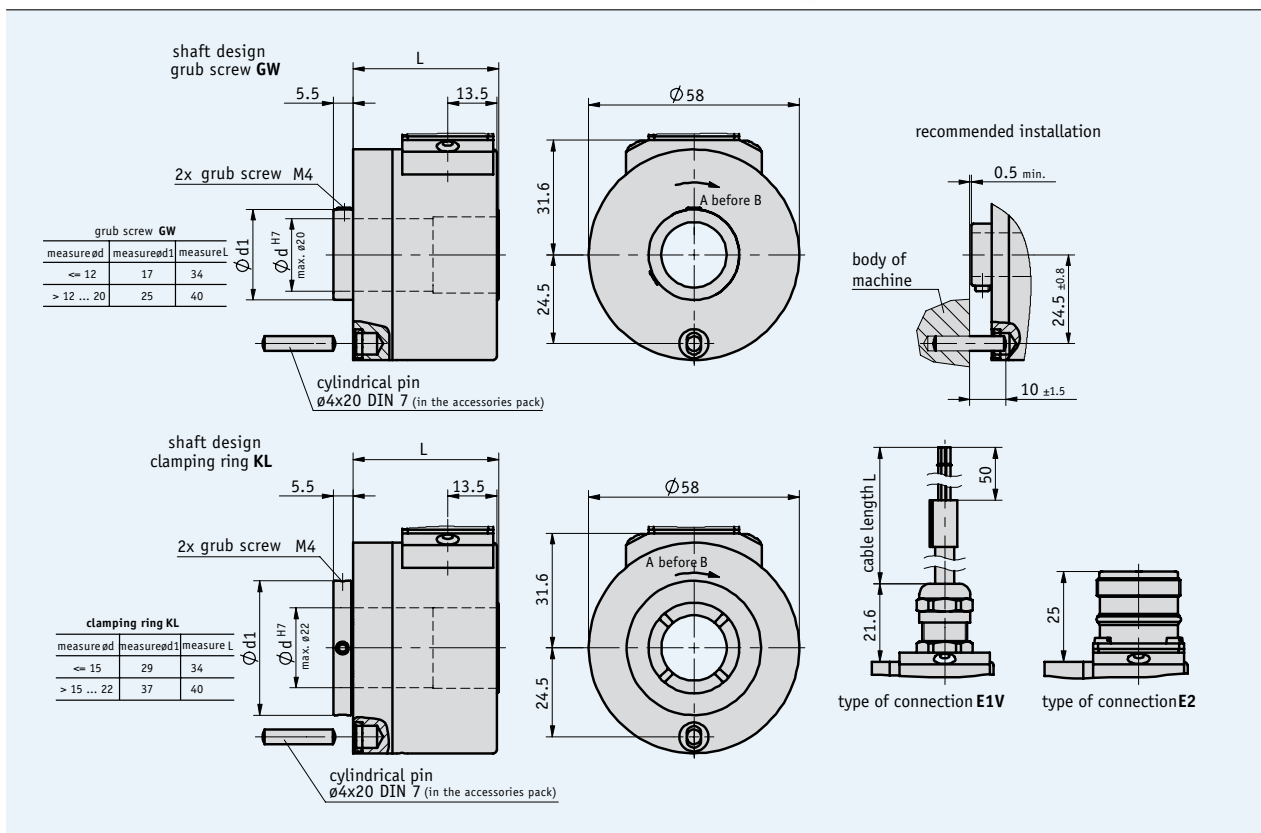

2.1



Mechanical data

Feature	Technical data	Additional information
Max. speed	6000 rpm	
Shaft moment of inertia	$\sim 0.3 \times 10^{-6} \text{ kgm}^2$	
Starting torque	$\leq 4 \text{ Ncm}$	at 20 °C
Weight	$\sim 0.4 \text{ kg}$	
Protection category	IP65	
Operating temperature	-20 ... +100 °C	
Storage temperature	-20 ... +100 °C	
Shock resistance	200 g/6 ms	according to DIN EN 60068-2-27
Vibration resistance	10 g/50 Hz	according to DIN EN 60068-2-6
Shaft	stainless steel	
Housing	aluminum	
Cable sheath	PUR $\varnothing 4.8 \text{ mm}$	

Electrical data

Output circuit

Feature	PP, OP Push-pull	LD5 Line driver	LD24 Line driver	Additional information
Operating voltage	+10 ... +30 V DC	+5 V DC $\pm 5\%$	+10 ... +30 V DC	
Current consumpt. w/o load (typ.)	<25 mA	<25 mA	<25 mA	ABO variant
Maximum load/channel	± 30 mA	± 30 mA	± 30 mA	
Max. pulse frequency	100 kHz	100 kHz	100 kHz	
Phasing	$90^\circ \pm 15^\circ$	$90^\circ \pm 15^\circ$	$90^\circ \pm 15^\circ$	
Signal level high (min.)	29.2 V DC			UB = 30 V, IOH = -30 mA
Signal level low (max.)	0.5 V DC			UB = 30 V, IOL = 30 mA
Signal level		RS422 A spec.	RS422 A spec.	
Inverse-polarity protection on UB	yes	no	yes	

Signal image

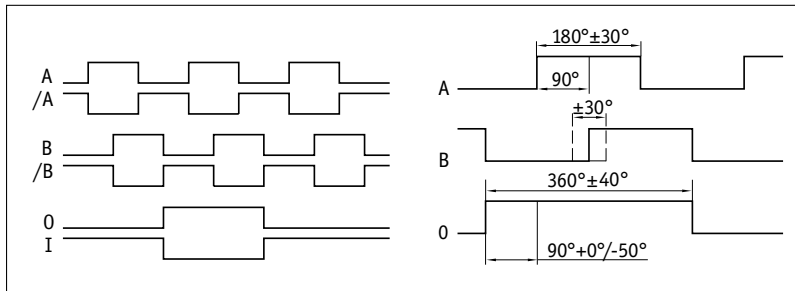

2.1

Pin assignment

Output circuit PP

Signal	E1V	E2
N.C.		1
N.C.		2
O/I	green	3
N.C.		4
A	yellow	5
N.C.		6
N.C.		7
B	white	8
N.C.		9
GND	gray	10
N.C.		11
+UB	brown	12

Output circuit LD5

Signal	E1V	E2
/B	blue	1
+SUB	violet	2
0	green	3
/0	red	4
A	yellow	5
/A	pink	6
N.C.		7
B	white	8
N.C.		9
GND	gray	10
SGND	black	11
+UB	brown	12

Output circuit OP, LD24

Signal	E1V	E2
/B	blue	1
N.C.		2
0	green	3
/0	red	4
A	yellow	5
/A	pink	6
N.C.		7
B	white	8
N.C.		9
GND	gray	10
N.C.		11
+UB	brown	12

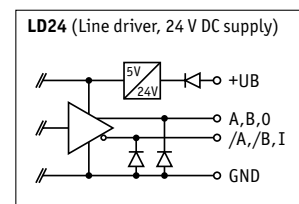
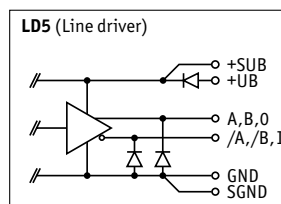
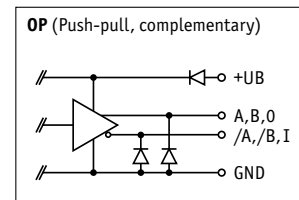
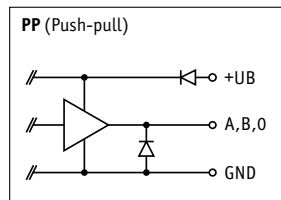

Order

Order table

Feature	Order data	Specification	Additional information
Output signals	... A	ABO, ABI, ABX	
Pulses/revolution	... B	50, 64, 100, 128, 200, 250, 256, 320, 400, 500, 512, 640, 800, 1000, 1024, 1280, 1600, 2000, 2048, 2560 others on request	
Type of connection	E1V E2 C	PG screwing connector	
Cable length L (m)	... OK D	0.2, 0.3, 0.5, 1, 2, 3, 4, 5, 6, 7, 8, 10, 20 without cable	only with E2
Output circuit	PP OP LD5 LD24 E	push-pull push-pull with inverted signals line driver line driver	
Shaft design	GW KL F	set screw clamp ring	
Shaft diameter	... G	6, 7, 8, 9.525, 10, 12, 14, 15, 15.875, 18, 19, 19.05, 20, 22	
Ambient condition	S E H	condensation not permitted condensation permitted	

Order code

IH58M - - - - - - - -

A B C D E F G H

Scope of delivery: IH58M, User information

Accessories:

Mating connectors

Page 88

Cable extension

Page 90

Electronic displays MA55, MA10/4

Catalog 6 DisplayLine

Additional information:

General information and areas of application

Page 8 cont.