



## SGH | 用于液压缸的位置传感器

### SGH POSITION SENSORS

### FOR HYDRAULIC CYLINDERS



#### 液压缸中的位置检测 - 简便， 坚固，耐用！

SGH系列拉绳编码器可以在液压缸中测量液压缸行程以及速度，并通过高效率、灵活性和坚固性打动人心。

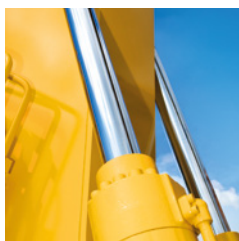

#### 应用优势：

- 液压缸位置的绝对式检测
- 直接集成在液压缸中
- 测量范围达 5000 mm
- 可用于高达 PLd 级别的安全应用
- 无需在活塞上钻孔
- 也可用于伸缩式缸体和 活塞式蓄能器
- 凭借 IP6K9K 防护等级可得到优越保护
- 耐用并且坚固-根据移动液压技术要求研发
- 电磁兼容性强



#### Position detection in hydraulic cylinders - simple, robust, durable!

The draw-wire encoders of the SGH series measure the cylinder stroke as well as its speed in the hydraulic cylinder with impressive efficiency, flexibility and robustness.

#### Advantages for the applications:

- Absolute detection of the cylinder position
- Direct integration into the cylinder
- Measuring range up to 5000 mm
- Can be used in safety applications up to PLd
- No drilling of the piston required
- Can also be used in telescopic cylinders and piston accumulators
- Perfectly protected due to protection category IP6K9K
- Durable and robust - developed in line with mobile hydraulic requirements
- High EMC

**每种应用都有适合的传感器**  
**The right sensor for all applications**

**SGH10 简介**

- 测量范围 0 ... 1000 mm
- 紧凑的结构设计 - 只有 45 mm x 63 mm
- 适用于特别紧凑的液压缸
- 高度灵活性，可通过示教功能对每个测量长度进行调整

**Profile SGH10**

- Measuring range 0 ... 1000 mm (39.37 inch)
- Compact design - only Ø 45 mm x 63 mm
- Suitable for particularly compact cylinders
- High degree of flexibility, can be adjusted to any measuring length with teach-in function



**SGH10L 功能简介**

- 测量范围 0 至 1000 mm
- 独特的侧面安装方式
- 几乎没有行程损失
- 高度灵活性，借助示教功能可调节
- 适配所有测量长度

**Profile SGH10L**

- Measuring range 0 ... 1000 mm (39.37 inch)
- Unique lateral mounting
- Nearly no loss of stroke
- High degree of flexibility, can be adjusted to any measuring length with teach-in function



**SGH25 简介**

- 测量范围 0 ... 2500 mm
- 紧凑的结构设计 只有 75 mm x 60 mm
- 高度灵活性，可通过示教功能对每个测量长度进行调整
- 也提供冗余接口
- 可用于高达 PLd 等级的安全条件苛刻的应用

**Profile SGH25**

- Measuring range 0 ... 2500 mm (98.42 inch)
- Compact design - only Ø 75 mm x 60 mm
- High degree of flexibility, can be adjusted to any measuring length with teach-in function
- Also available with redundant interface
- Can also be used for safety-critical applications up to PLd



**SGH50 简介**

- 测量范围 0 ... 5000mm
- 紧凑的结构设计 只有 100 mm x 60 mm
- 高度灵活性，可通过示教功能对每个测量长度进行调整
- 也提供冗余接口
- 可用于高达 PLd 等级的安全条件苛刻的应用

**Profile SGH50**

- Measuring range 0 ... 5000 mm (196.85 inch)
- Compact design - only Ø 100 mm x 60 mm
- High degree of flexibility, can be adjusted to any measuring length with teach-in function
- Also available with redundant interface
- Can also be used for safety-critical applications up to PLd

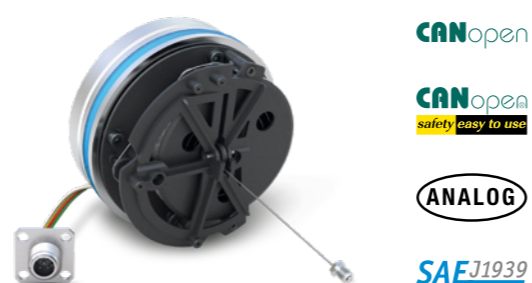

**技术 - 坚固，耐用，革命性!**

SGH 传感器使用拉绳机构来检测行程，该传感器直接安装在液压缸内部。线绳的拉绳机构被固定在活塞头上，当液压缸移出时，缠绕在线绳卷筒上的绳索被拉出。由此产生的卷筒旋转运动被传感器非接触式的检测到，并转化为线性位移，因此可随时获得准确而绝对的液压缸位置值和速度值。用于检测旋转运动的磁铁被SGH传感器的耐压底板非接触式的扫描。电子装置被完全封装在系统的非加压侧，整个测量系统被安装在液压缸内部，从而可最佳的防止其受到外部环境条件的影响。明显的优势: 与安装在气缸外部的测量系统不同，该传感器系统不会被损坏或者受到环境的负面影响甚至破坏。

**The technology - robust, durable, revolutionary!**

SGH sensors use a draw-wire mechanism that is integrated directly into the cylinder to measure the stroke. The wire of the draw-wire mechanism is secured to the piston head. When the cylinder extends, the wire wound on a wire drum is pulled out. The resulting rotation of the drum is detected by the contactless sensor system and converted into a linear position. This means that precise and absolute position or speed tracking of the cylinder is possible at any time. The magnets used to measure the rotation are scanned by the contactless sensor system through the pressure-resistant base plate of the SGH sensors. The electronic components are fully encapsulated and located on the non-pressurised side of the system. The entire measuring system is therefore incorporated into the cylinder and optimally protected against external environmental influences. Clear advantage: in contrast to measuring systems mounted externally on the cylinder, the sensor system cannot be damaged, negatively affected or even destroyed by environmental conditions.

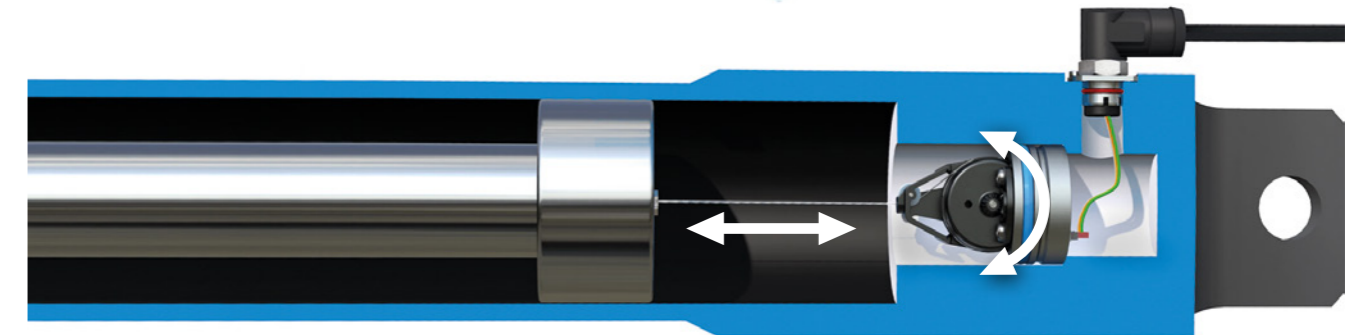

**用于移动液压系统中困难条件下应用的研发!**

SIKO 的 SGH 传感器是根据知名液压缸生产商的严格规格进行设计和研发的。因此SIKO 非常明确，产品的坚固性、耐用性和功能性必须要符合市场的要求。因此要与液压缸生产商密切的合作，对使用寿命，抗冲击和抗震性，电磁兼容性以及与不同液压介质的兼容性的要求进行了定义和转化。所有这些规范已经在液压缸制造商的使用寿命测试中或外部认可的实验室中得到了验证和确认。作为拉绳编码器的首家生产商，SIKO 在研发和设计方面拥有30年的拉绳编码器的专业技术经验。因为这体现了公司的核心技术，所以全部传感器组件的整体设计工作都是在公司内部完成的。由此确保了传感器能够满足移动液压系统的高要求。

**Developed for the tough conditions in mobile hydraulic applications!**

The SIKO SGH sensors were designed and developed in line with the strict specifications of renowned hydraulic cylinder manufacturers. For SIKO it is clear that the demands regarding robustness, durability and functionality must meet market requirements. Therefore, SIKO worked closely together with cylinder manufacturers to define and satisfy the specifications regarding service life, shock and vibration resistance, EMC and compatibility with various hydraulic media - without compromises. All these specifications were tested and confirmed in endurance tests at the facilities of cylinder manufacturers or in external accredited laboratories. As one of the first draw-wire encoder manufacturers, SIKO profits from the development and design know-how of 30 years. As this is one of the core competencies of the company, all sensor components are also fully designed on the company's premises. This ensures that the sensors do justice to the high mobile hydraulics demands.



测量范围 (max.)   Measurement Range (max.)	SGH10	SGH10L	SGH25	SGH50
≤ 1000 mm (39.37 inch)	X	X	X	X
≤ 2500 mm (98.42 inch)			X	X
≤ 5000 mm (196.85 inch)				X

切换点   Interfaces	SGH10	SGH10L	SGH25	SGH50
模拟   Analogue	X	X	X	X
CANopen	X	X	X	X
SAEJ1939	X	X	X	X
模拟 冗余   Analogue redundant			X	X
CANopen 冗余   CANopen redundant			X	X
SAEJ1939 冗余   SAEJ1939 redundant			X	X
CANopen Safety			X	X

构造形式   Safety Model	SGH10	SGH10L	SGH25	SGH50
PLd			X	X

E1认证   E1 Certification	SGH10	SGH10L	SGH25	SGH50
E1 (UN ECE R10)	X	X	X	X

工作电压   Operating Voltage	SGH10	SGH10L	SGH25	SGH50
9 ... 32 VDC	X	X	X	X
12 ... 32 VDC	X	X	X	X

保护类型   Protection Category	SGH10	SGH10L	SGH25	SGH50
IP6K9K	X	X	X	X

安装方式   Mounting	SGH10	SGH10L	SGH25	SGH50
集成的   Integrated	X		X	X
横向栽培   Lateral mounting		X		

### 用于智能液压缸的智能传感器!

SGH 技术将液压缸和伸缩式液压缸以及活塞储能器转化为智能的液压缸和液压系统。在此，针对每一种应用都能提供一个合适的传感器。具有长达5000毫米的测量长度和种类繁多的接口以及高度灵活的传感器集成，让 SGH 传感器提供了广泛的传感器系列为您所用。对于安全条件苛刻的应用，冗余传感器适配达到性能等级 d (PLd) 的应用。

### Intelligent sensors for smart cylinders!

The SGH technology transforms hydraulic and telescopic cylinder as well as piston accumulators into smart cylinders and hydraulic systems. A suitable sensor is available for all applications. With measuring lengths of up to 5000 mm, a wide selection of interfaces as well as high flexibility for integration of the sensors, the SGH family offers a wide range of possibilities. Redundant options and sensors for performance levels of up to PLd are available for safety critical applications.

### 安全可靠的定位检测

智能传感器将移动液压系统的安全性和效率提高到一个新的水准。功能安全性，这个概念所有人都在说。不仅从新的机械准则 EN 13849 实施开始，安全性准则是移动机械领域的一个重要话题。SIKO 的 SGH 系列传感器有助于实现移动机械的智能化安全理念，并满足各种载货车辆特定安全标准的严格要求。

SGH25 和 SGH50 传感器的安全型号可满足性能等级达到 d PLd 的应用要求。根据CAT3的安全和冗余设计以及安全的机械设计，体现了我们的产品即使在特殊的条件下也适用于安全条件苛刻的应用。

### Reliable position tracking

Smart sensors take mobile hydraulics to a new level of safety and efficiency. "Functional safety" is a term that is being widely discussed. Safety concepts for mobile machinery have not only been a topic of interest since the implementation of the Machinery Directive EN 13849. Sensors of the SIKO SGH range help implement intelligent safety concepts for mobile machinery and meet the requirements of the specific safety standards for different utility vehicles.

The safety versions of the SGH25 and SGH50 sensors meet the requirements for use in applications up to Performance Level d (PLd). Safe and redundant design in compliance with CAT3 as well as a safe mechanical design means that our products are predestined for use in safety-critical applications, also under unusual conditions.



此外，传感器提供的过程数据不仅符合安全要求，而且为机器增值。通过这种方式，过程数据可以提供关于可能需要的维护间隔的信息。起重机和起重技术中灵活的支撑检测扩展了机器的工作区域。地面运输车辆的记忆功能可以节省时间并使工作更安全。所有这些只是关于 SGH 传感器如何使您的机器不仅更安全而且更高效的几个例子。

In addition, the sensors supply process data which not only serve to satisfy safety requirements, but also offer an added value for the machine. The process data can therefore provide insight into an impending seal maintenance interval. Flexible support tracking in crane and lifting applications extend the working ranges of the machine. Memory functions in industrial trucks save time and make work safer. All these are examples of how SGH sensors not only make your machinery safer, but also more efficient.



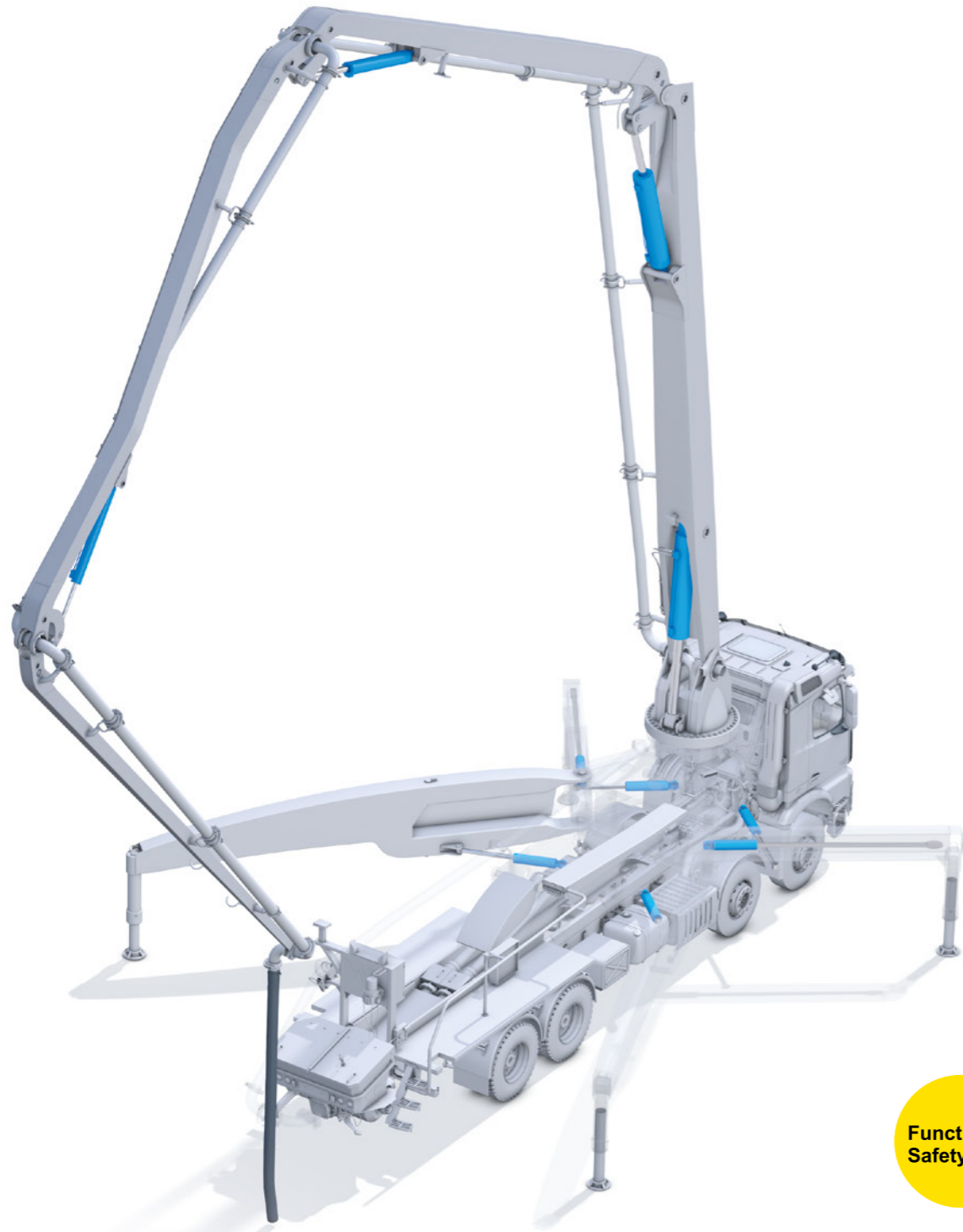

**这可能吗？当然可能。  
负载转矩限值**

液压缸内的精确位置检测提高了载货车的安性！SGH传感器适用于高达性能等级d PLd 的安全条件苛刻的应用！

**Is this possible? Sure it is.  
Load moment limitation!**

Exact position tracking in the cylinder enhances safety in utility vehicles! SGH sensors are suitable for safety-critical applications up to Performance Level d (PLd)!



**成熟的检测原理被优越保护！**

拉绳编码器一直是工地地面运输车辆中位置检测的重要组成部分。通过智能SGH传感器，这些传感器现在也可以在任何环境条件下得到保护，并且可以在不损失行程的情况下集成到车辆中。

**Track-proven detection principle, perfectly protected!**

Draw-wire encoders have been an important element of position tracking in industrial trucks for some time. With the smart SGH sensors these are now also protected against all environmental conditions and can be integrated into the vehicle without any stroke losses.

伸缩式液压缸  
Telescopic cylinders



SIKO SGH Position Sensors for Hydraulic and Telescopic Cylinders - Measuring length 0 to 5 m

全球首创：  
在伸缩式液压缸中的位置检测。

SGH传感器首次能够利用完全集成的传感器来检测伸缩式液压缸的位置。简单，创新，灵活！

*A world first: position tracking in telescopic cylinders.*

*With the SGH sensors it is now possible for the first time to track the position of telescopic cylinders with a fully integrated sensor. Simple, innovative, flexible!*

活塞式蓄能器  
Piston accumulator

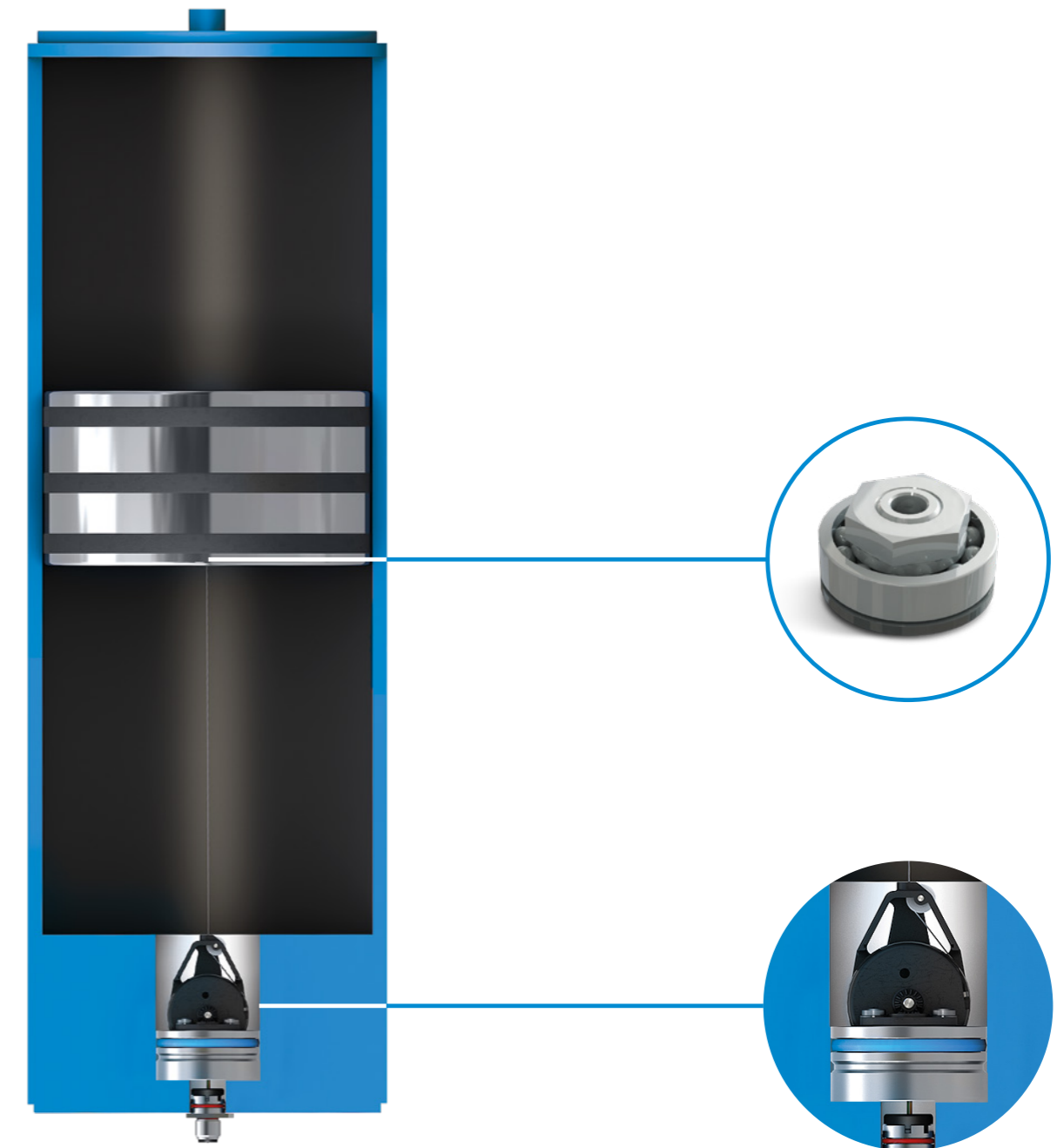

活塞蓄能器中的位置检测  
时刻关注灌装水平

SIKO 位置传感器也非常适合用于活塞式蓄能器。通过 SGH 传感器安装于活塞式蓄能器的气体区域中，可以达到节省空间和高效的方式安装的效果，以利于提供有关运行状态的信息，例如 灌装量。

*Tracking the position in the piston accumulator - keeping a constant eye on the filling level*

*SIKO position sensors are also in a class of their own for use in piston accumulators. For example, the SGH sensors can be mounted in the gas area of the piston accumulator in a space-saving and efficient way to obtain information about the operating status, such as filling level.*

## 活塞无需钻孔

由于独特的设计和拉绳编码器原理，活塞无需钻孔！因此可轻而易举的实现高效和低成本相结合。

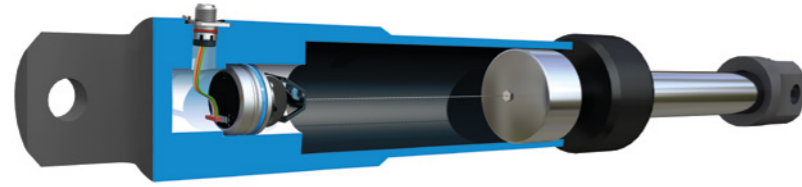

## Piston drilling not necessary!

Due to the unique construction and the draw-wire encoder principle it is not necessary to drill the piston! Efficient and inexpensive integration is child's play.

## 安装简易 - 只需要几个步骤就可安装

SGH 拉绳编码器 通过几个简单的步骤就可以安装，由于它创新的插头系统，使结合变得简易，可满足 IP6K9K 的防护等级。通过这样保证 SGH 能够最好的被保护不受环境的影响。

## Simple installation - fitted in a flash

The SGH draw-wire encoder can be fitted in a few simple steps. With its innovative connector system, integration is easy and meets the requirements of protection category IP6K9K. As a result the SGH is effectively protected against environmental influences.

- 1 红色的连接插头可卡入传感器  
The red connector is inserted into the sensor with one click.



- 2 插头系统从预先钻好的孔洞中引出。  
The connector system is routed out of the hole provided.

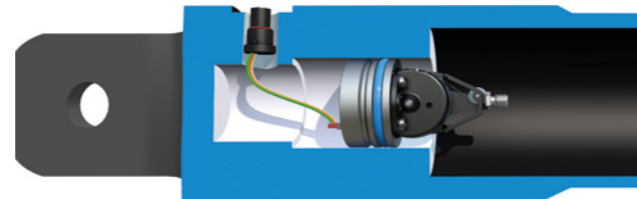

- 3 插头卡入法兰中然后通过四个螺钉安装在气上。  
The connector insert is then clicked into the flange and mounted on the cylinder with four screws.



- 4 完成！在插入的状态系统能够满足防护等级 IP6K9K！  
Finished! When connected, the system meets the stringent requirements of IP6K9K!

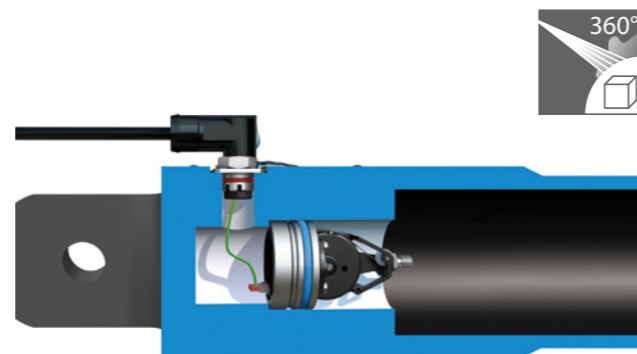

## 用于智能化液压缸的智能传感器

空间问题已成为过去！SGH 系列拉绳编码器可以灵活地集成到几乎任何车辆中，即使在空间非常紧凑的情况下。通过拉绳功能原理，传感器可以简便、经济而高效地集成到几乎任何液压缸设计中。由于传感器没有死区或阻尼区，因此可以从“第一个毫米”进行测量。

## Intelligent sensors for smart cylinders

Space problems are a thing of the past! Draw-wire encoders of the SGH series can be flexibly integrated into almost all vehicles, even when space is tight. With the draw-wire functional principle the sensors can be simply, cheaply and efficiently integrated into almost any cylinder design. As the sensors do not have any dead or damping zones, measurement is possible from the "first mm".

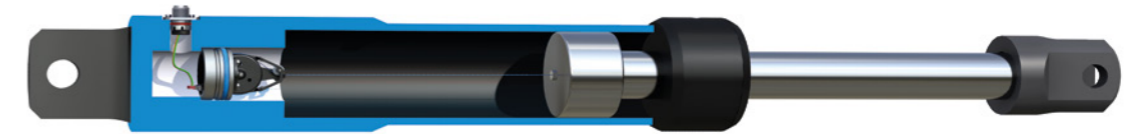

## 高度集成结构达到无行程损失效果！侧面安装方式的可能性

由于独特的横向安装方式，SGH10L 传感器也可以用于几乎无法解决的应用方案中。使用 SGH10L 传感器可将所需的安装空间减少到原本的 75%。无论是对于不允许行程损失的应用、极其微小的活塞直径、还是带有机械式终端位置缓冲装置的缸体 - SGH10L 都能提供完美的解决方案。

## Integration without stroke losses! Lateral mounting of the sensor possible

Thanks to its unique lateral installation, the SGH10L can be used in almost unsolvable applications. With the SGH10L sensor, the required installation space can be reduced by up to 75%. Regardless of whether for applications in which no stroke loss can be accepted, extremely small piston diameters or in the case of cylinders with mechanical end position cushioning - The SGH10L is the perfect solution.



## 我们竭诚为您服务

### 无论是本地客户 ...

您正在寻找附近的代理?我们的网站为您提供帮助, 通过

[www.siko-global.com](http://www.siko-global.com) 网址和输入邮政编码, 找到负责您的德国 SIKO 代理商的当前联系方式。

### ... 还是国际客户

SIKO 公司在全球范围由子公司和商业机构代理。通过

[www.siko-global.com](http://www.siko-global.com) 找到在您附近的 SIKO 合作伙伴。

## We are always there for you.

### Whether locally ...

Are you looking for an agency near you? Our website will help you.

At [www.siko-global.com](http://www.siko-global.com) you will find current contact data of a local German SIKO agency via your postal code.

Or just call us and we will give you the contact data you need.

### ... or internationally.

Subsidiaries and agents all over the world represent SIKO.

At [www.siko-global.com](http://www.siko-global.com) you will also find a SIKO partner in your area.



## SIKO Global



SIKO GmbH



SIKO Products Inc.



SIKO Italia S.r.l.



SIKO MagLine AG



SIKO International Trading (Shanghai) Co., Ltd.



SIKO Products Asia Pte. Ltd.

SIKO GmbH

Weiherrmattenweg 2  
79256 Buchenbach

Am Krozinger Weg 2  
79189 Bad Krozingen

Phone +49 7661 394-0

Fax +49 7661 394-388

E-Mail [info@siko-global.com](mailto:info@siko-global.com)

[www.siko-global.com](http://www.siko-global.com)

Follow "SIKO-global" and stay up to date!

